

Clean Room Equipment

Advanced Purification Technology



LENGE PURIFICATION

“ 25 years of experience in purification solution.
Innovative purification technology -
yesterday, today and in the future, since 1995. ”



LENGE purification equipment are the manufacturer of over 25 years of experience, expertise and research in air and liquid filtration. We offer innovative purification solutions that set standards and help factories to improve the quality of production.

Established in the year 1995, we are one of the leading manufacturers, exporters and distributors of Clean Room Equipment and System in China, "Purification Devices & Services" is a name to trust upon. We have been offering a large array of Horizontal, Vertical & Ceiling Suspended Type Laminar Airflow System, Powder Sampling & Dispensing Booth, Air Shower Entry System, Static & Dynamic Pass Box, Laminar Airflow Work Bench and Trolley, Bag In & Bag Out, VHP Sterilization Chamber, etc. We also offer Clean Room Stainless Steel Furnishings, such as Cabinet, Shoe Rack, Sink, Trolley, Drum&Bin, etc. To provide complete satisfaction to the clients, we have been offering customization solutions with after sales services to them as per their exact requirements.

Air filters series are superior products in LENGE. LENGE imported TOPAS ALF114 air filter detection line and AFS150 HEPA filter detection line from German to guarantee product quality. ALF114 can carry out tests on the medium efficiency filter according to EN779 and ASHRAE52.2, including air volume resistance, initial efficiency, dust capacity, etc. AFS150 can carry out test on HEPA filter according to EN1822, including air volume resistance, local efficiency, overall efficiency, etc.

With many of you, we have a long history: a reliable foundation on which to build our common future. That experience gives us the necessary confidence to do the right thing at the right time and equips each of us to meet the challenges of tomorrow.

We will continue to focus on partnership and proximity to our customers, far into the future. For innovative solutions that help to make industrial processes more efficient and sustainable to improve the quality of products.



ISO 45001:2018
Occupational Health and Safety
Management System
Certification



Halal Foundation Center
Halal Certification





Clean Room Equipment

LENGE is the leading manufacturer of critical purification applications, with over 20 years of design and fabrication experience in clean room and pharmaceutical, laboratory-based industries. LENGE Clean Room equipment range comprises high-quality cleaning systems and the associated service, and lay the foundation for the safe production of pharmaceuticals.



Design

Patents

LENGE purification devices currently have obtained 6 invention patents, and 12 utility model patents.

Circular Angle Design

Integrated circular angle are designed for the working area, no dead corners, dust-free, and easy to clean.

3D Design Drawing

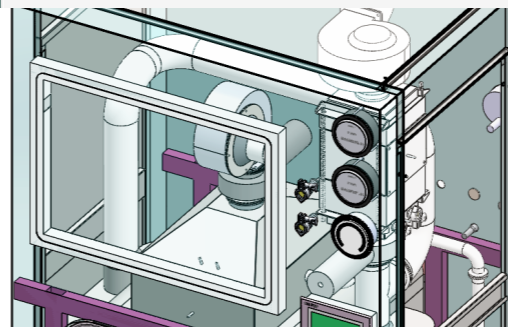

Property

Unidirectional Airflow in the Work Area

Pressure equalization design, uniform airflow, ensuring unidirectional airflow in the work area. Dust is collected by air filters in the equipment and does not diffuse.

Branded Components, High Quality

Branded fan, which has strong over pressure. Low noise and energy saving, giving us reliable performance.

Air Curtain, Elegant Appearance

Air curtain, in stead of PVC curtain, is safety and clean for separating work area and background.

Service

Installation&Verification

In addition to technical service to ensure reliable operation of our units and systems, we offer services that result in the on-site installation, and verification.

Product Quality Assurance System

Validation files for customers' URS, including FDS, DQ, FAT, IQQ, etc. All files could be traceable.

Maintenance service

Respond immediately within 24 hours when you have any problems with equipment.

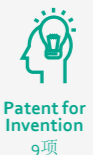

Patent for Invention
9项



Patent for Utility Model
13项



Equipment Assembly and Debugging



Site Acceptance Test



Large Volume Injection ▼

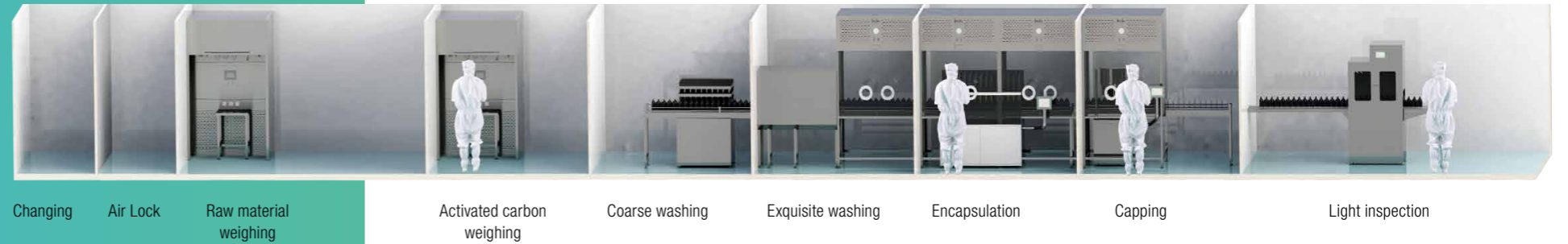

Sterile dispensing of injection ▼



Freeze-dried powder injection ▼



LENGE Purification is designed such that through the different configurations it can be applied; fit but not limited to the following markets:

- Pharmaceutical
- Clean Room Products
- Life Sciences
- Biological
- Food and Beverage
- Lab Animal Research Products
- Nutraceutical
- Micro-electronics
- Biological Safety Products
- Industrial Lab Equipment

Application

For the past twenty-five years we have been a leading supplier of purification equipment for clean rooms to the Pharmaceutical Industry. LENGE is viewed by over 1000 Pharmaceutical manufacturers as a partner and well positioned to support their air filtration demands.



Laminar Airflow System

Laminar air flow units with adjustable blower speed feature HEPA are a series of high efficiency products designed to protect equipment and other contents of the work zone from particulates to meet class A cleanliness requirements.



Characteristics and Features

- Provides HEPA filtered airflow through the work area that protects the sample from airborne contamination and assure sterility and minimizing cross contamination.
- Build-in LED light.
- Differential pressure gauge monitors filter pressure drop.
- Movable uniform membrane, wind speed will be uniformly distributed.

Airflow Schematic

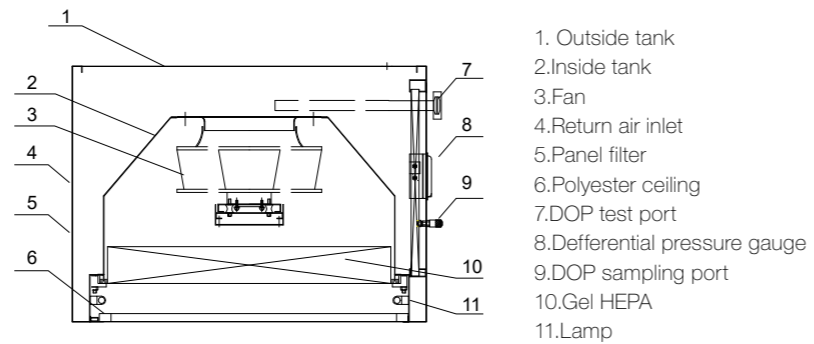
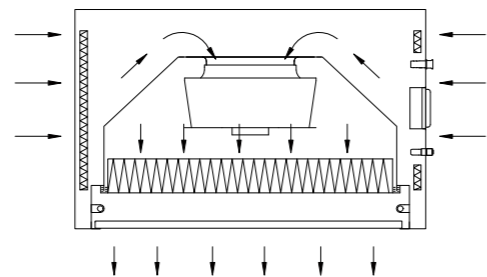

1. Outside tank
2. Inside tank
3. Fan
4. Return air inlet
5. Panel filter
6. Polyester ceiling
7. DOP test port
8. Defferential pressure gauge
9. DOP sampling port
10. Gel HEPA
11. Lamp

Containment System

- Economical laminar flow cabinet with clean, simple, low-maintenance design is a work bench with Class A environment can be used in assembly, testing and inspection procedures that require a continuous flow of ultra clean air.
- Provide a sterile positive pressure environment for the compounding of Sterile Products.
- Integrated fan filter module with low noise & watt fan.

Engineering Drawing

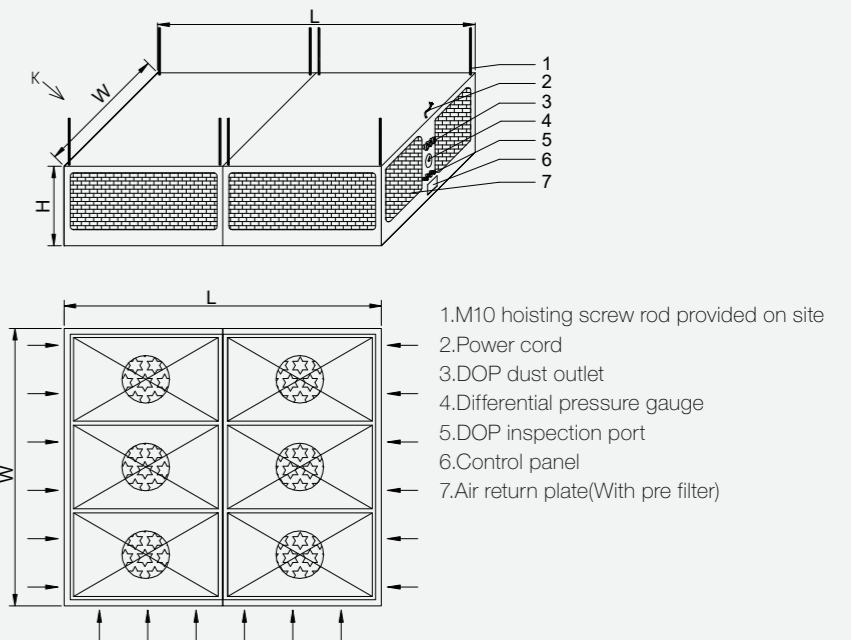

- 1.M10 hoisting screw rod provided on site
- 2.Power cord
- 3.DOP dust outlet
- 4.Differential pressure gauge
- 5.DOP inspection port
- 6.Control panel
- 7.Air return plate(With pre filter)



Dimensions

Model	Outer Size LxWxH(mm)	Inner Size L'xW'(mm)	Rated Air Velocity (m/s)	Cleanliness Class	Noise (dB)
LUFH12-120060	1200×600×650	1200×600	0.45±20%	Class A	65-75
LUFH16-100100	1000×1000×650	1000×1000			
LUFH32-200100	2000×1000×650	2000×1000			
LUFH35-180120	1800×1200×650	1800×1200			
LUFH47-240120	2400×1200×650	2400×1200			
LUFH49-200150	2000×1500×650	2000×1500			
LUFH65-200200	2000×2000×650	2000×2000			

Dispensing Booth

Dispensing booth is an advanced containment system which provides controlled negative pressure environments to maximize personnel protection during weighing and sampling process. LENGE provide standard configurable designs which is able to adapt to various weighing and sampling requirements.

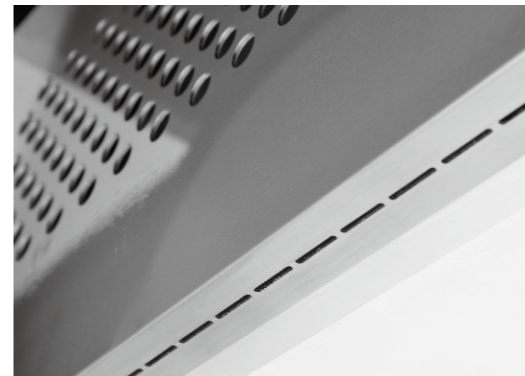

Containment System

- Main Stream - The opening provides an airflow velocity of 0.45 m/s.
- Equipped with control system.
- Standard controls suitable for safe area applications.
- Includes electrical sockets as standard.
- RH/Temperature sensor.
- HEPA filter to provide high level of filtration.
- Emergency stop.
- HEPA fan module provides laminar flow of particlefree air (measured at 0.3µm particles) to meet clean room requirements—99.995% efficient ULPA filters also available.
- Filter Module
 - Pre filter -- Panel filter G4
 - Comfort filter -- Bag filter F8
 - HEPA filter -- Gel sealed mini-pleated HEPA filter H14
- Fan modules includes 99.995% efficient HEPA filter to ensure clean working conditions.
- 380V, can be customized.

Engineering Drawing

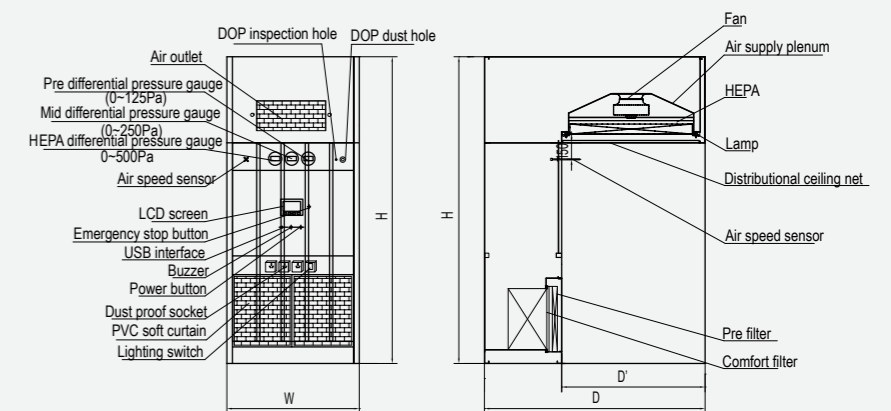

Characteristics and Features

- Cross contamination control through negative pressure environment option.
- Full unidirectional airflow provides superior aseptic work zones.
- Fully welded single piece SUS304 internal chambers with rounded covered corners.
- Clean interior and exterior finishing.
- cGMP modular design with minimized joints and seams.
- Gel seal HEPA filters, HEPA/ULPA gel sealed design is better than conventional gasket sealed.
- Dimensions are customized to suit process requirements.
- All components meet or exceed applicable safety requirements.

Airflow Schematic

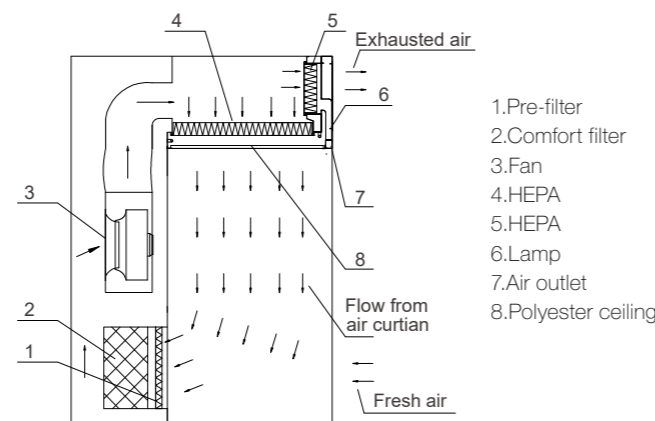

Dimensions

Model	Outer Size WxDxH(mm)	Inner Size W'x'D'x'H'(mm)	Rated Air Velocity (m/s)	Cleanliness Class	Power (kW)
LWR 13-120060	1300x1200x2570	1200x600x2000	0.45±20%	Same as the background area	0.8
LWR 34-150120	1600x1800x2570	1500x1200x2000			2
LWR 75-200200	2100x2800x2570	2000x2000x2000			4
LWR 112-300200	3100x2800x2570	3000x2000x2000			4
LWR 186-400250	4100x3300x2570	4000x2500x2000			7.5

Pass Box

Pass box is an equipment used for transfer of goods, and could segregate the air on both sides of the room. It is installed at the entrance to Clean Room in order to minimize the amount of particulate contamination entering the Clean Room.



Containment System

- Manufactured for the most demanding controlled environment applications.
- Mechanical or electronic interlock is reliable, maintenance-free, fail safe and maintains Clean Room integrity by preventing both doors from being opened at the same time.
- Excellent to avoid cross contamination.
- All components are designed for maximum chemical resistance and enhanced durability for a long service life.
- The internal side walls of the pass box are constructed from a single piece of stainless steel, with coved corners for easy cleaning.
- Tempered glass doors provide visibility into the interior.
- Frameless construction is easy to clean with no joints for contaminants to accumulate.
- Stainless steel frame, and double-deck 5mm thick tempered glass door.

Classification

- Dynamic pass box.
- Static pass box.

Characteristics and Features

- Tempered glass doors provide a clear view of the internal chamber.
- The main body of the pass box is constructed of SUS 304/316L stainless steel.
- Variety of accessories and dimensions.

Airflow Schematic

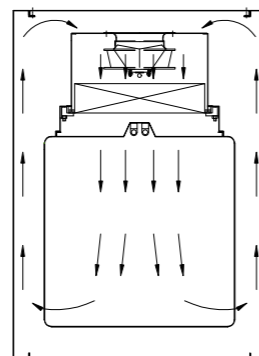

Airflow Direction

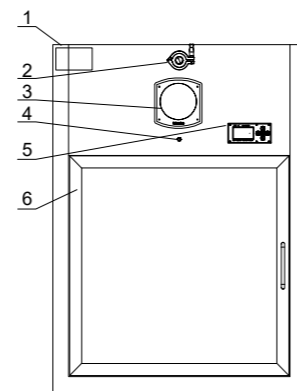

Drawing of Structure

- 1.Box
- 2.DOP test port
- 3.Differential pressure gauge
- 4.DOP sampling
- 5.Control panel
- 6.Double layer tempered glass door

Dynamic Pass Box

Model	Outer Size WxDxH(mm)	Inner Size W'D'xH'(mm)	Rated Air Velocity (m/s)	UV Lamp (W)	Noise (dB)	Power (kW)
LCTW3-040040	620x460x950	400x400x400	0.45±20%	6x2	65	0.2
LCTW4-050050	720x560x1050	500x500x500		8x2		
LCTW6-060060	820x660x1150	600x600x600		8x2		
LCTW6-060080	820x660x1350	600x600x800		8x2		
LCTW8-070070	920x760x1250	700x700x700		15x2		
LCTW10-080080	1020x860x1350	800x800x800		20x2		
LCTW16-100100	1220x1060x1600	1000x1000x1000		20x2		

Static Pass Box

Model	Outer Size WxDxH(mm)	Inner Size W'x'D'xH'(mm)	UV Lamp (W)
LTW-040040	620x460x640	400x400x400	6x2
LTW-050050	720x560x740	500x500x500	8x2
LTW-060060	820x660x840	600x600x600	8x2
LTW-060080	820x660x1040	600x600x800	8x2
LTW-070070	920x760x940	700x700x700	15x2
LTW-080080	1020x860x1040	800x800x800	20x2
LTW-100100	1220x1060x1240	1000x1000x1000	20x2

Bag In/Bag Out

The LENGE Bag In/Bag Out side access filter system is a safe, simple, reliable method for removing contaminated particulate filters and/or gas absorbers used for air purification in hazardous environments. With this system, maintenance personnel are protected from coming in direct contact with the interior of the housing and hazardous contaminants during filter change-out.



Characteristics and Features

- Manufactured from powder-coated cold-rolled sheet or 304 stainless steel and 316 stainless steel for option.
- Housing accommodates standard gel seal HEPA filters and prefilter.
- All pressure boundaries are fully welded.
- Multi-wide housings are equipped with a filter removal rod to draw the filters to the change out position.
- One PVC change out bag is furnished for each filter access port.
- Deep Adsorber Housing: Housings are available for 12", 16" and 18" filter cells. When additional residence time is required, these units can be furnished in series, or operated at lower face velocities.
- Upstream Filter Seal: Each HEPA filter seals against the air entering face of the frame to prevent interior contaminant build-up.

Containment System

- **Three Filters Per Door**
Units up to three filters wide are serviced through only one door. Two doors are furnished with units four through six filters wide, one on each side of the housing.
- **Separate Door**
Each filter component, prefilter, HEPA filter, and adsorber filter is furnished with an individual door with protective bag to allow selective, safe, and economical service.
- **External Flanges**
All housing flanges are turned out for ease of field connection and to keep them out of the contaminated gas stream, ensuring smooth non-turbulent airflow.
- **Standard Final Filters**
The basic housing is designed for standard 24" x 24" x 11½" HEPA filters or carbon adsorber cells. LENGE designs and manufactures a full line of HEPA filters and adsorber cells. Filters include high-capacity HEPA filters for service up to 2,000 CFM each.
- **Door Details**
Door showing gasket, also pictured are optional lifting lugs, pressure taps, and weather cover.
- **External Locking Mechanism**
All gasket seal filters and adsorbers are furnished with a replaceable clamp type locking mechanism which is actuated from outside the housing. Filter seals can be "fine-tuned" as needed without opening the door. An optional security device is available to turn an external locking mechanism into an internal locking mechanism. This requires that the door be opened for the locking mechanism to be activated.
- **Internal Locking Mechanism**
All fluid seal filters are sealed using an internally actuated locking arm.
- Flow of particlefree air (measured at 0.3µm particles) to meet clean room requirements—99.995% efficient ULPA filters also available
- **Filter Module**
- **Pre filter** -- Panel filter G4
- **HEPA filter** -- Gel sealed mini-pleated HEPA filter H14
- Fan modules includes 99.99% efficient HEPA filter to ensure clean working conditions.

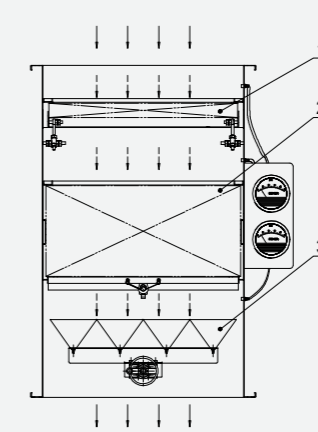

Airflow Direction
 1.Pre-filter
 2.HEPA filter
 3.Scanner

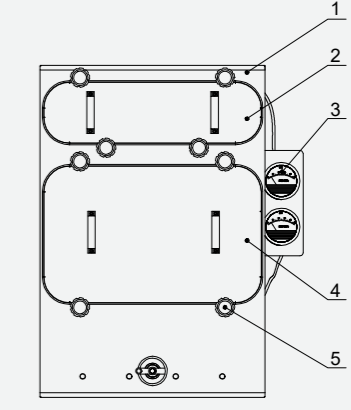

Drawing of Structure
 1.Box
 2.Cover Plate of Pre-filter
 3.Differential Pressure Gauge
 4.Cover Plate of HEPA filter
 5.Aluminum Corrugated Hand Wheel

Dimensions

Model	Outer Size WxDxH(mm)	Filter Size LxWxD(mm)	Air Velocity (m ³ /s)
LWB1700	400x725x900	305x610x292	1700
LWB3400	705x725x900	610x610x292	3400
LWB5100	705x1175x900	*	5100

*Note: specifications listed in the table are only for customers' reference. It may be designed and manufactured according to customers' URS. * indicates that this specification needs two sizes of air filter are 305x610x292 and 610x610x292.

Air Shower/Spray Blowing Shower

Air Shower

This air shower is used for the decontamination of personnel before entering clean rooms for avoiding contamination. Personal and materials entering or exiting the controlled environment are "scrubbed" by high velocity HEPA filtered air jets. Contaminated air is then drawn complete the base within the unit filtered and recirculated.

Spray Blowing Shower

Besides the function of air blowing in the ordinary air shower, the function of water spray blowing is also increased. It is applicable to "toxic dust" in medicine, chemical enterprises. A high pressure pump is used to compress the water into a fine spray through the copper nozzle, which can wet dust adhered to overalls and keep staffs' clothing dust from fluttering



Spray Blowing Shower

- Spray blowing shower will form a low flow of wet spray, can contaminate the work clothes of the raw material powder particles coating, continue to condense into large material particles.
- The high speed airflow around the large particle material will prevent the dust particles from contacting the droplets, while the small droplets of the micro particles are easy to condense the dust particles.
- Large particles of material are deposited on the surface of the filter or in the swag collection tray by high-speed airflow. The production of droplets can quickly reach air saturation.
- Moisten all surfaces and form beads on clothing. As time goes on, the water drops gradually increase until they roll off the clothes.

Technical Specification

Cleanliness
Class D or higher

Temperature
5°C~40°C

Engineering Drawing

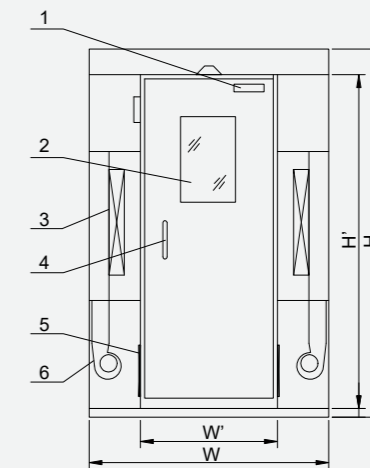

1. Door closer
2. Tempered glass
3. HEPA filter
4. Door handle
5. Pre-filter
6. Fan

Air Shower

- High velocity shower jets in excess of 25m/s ensure efficient scrubbing action to remove particulate matter.
- Operating modes can be programmed in the field.
- Control panel supervises all functions.
- HEPA filter, filtration achieves > 99.99% typical efficiency at 0.3 micron particles.
- A disposable pre-filter G4 extends the life of the main filter.
- An emergency stop button is mounted on sides of the shower.
- Auto-Inductive when people come into the booth and the air nozzle begin to work.
- Permanently lubricated direct drive centrifugal blowers are used in conjunction with stainless steel air nozzles.
- Interlock Door System.

Technical Specification

Power supply
380V50Hz

Power
1.5kW

Noise
65-75dB(A)

Differential pressure gauge
High efficiency display differential pressure gauge

Buzzer
Pressure difference, fault alarm

Button
Power supply (luminous ring visible buttons) with emergency stop

Dimensions

Model	Outer Size W×D×H(mm)	Inner Size W'×D'×H'(mm)	Nozzle Speed Rating (m/s)	Number of Nozzle	HEPA Size L×W×D(mm)/Quantity
ASR-080090	1200×1000×2150	800×900×1950	25	6	650×650×93 /1
ASR-080090	1400×1000×2150	800×900×1950		12	650×650×93 /2
ASR-080140	1400×1500×2150	800×1400×1950		18	955×650×93 /2
ASR-080190	1400×2000×2150	800×1900×1950		24	650×650×93 /4
ASR-080290	1400×3000×2150	800×2900×1950		36	955×650×93 /4

Laminar Airflow Work Bench

LENGE laminar flow clean bench is the premium selection for the discerning researcher, offering a combination of value, high quality construction, low operating noise levels, and a wide product range to suit all budgets, from the industry leader.



Advantages

- Quiet airflow design offers noticeably reduced noise level.
- SUS304 interior for enhanced resistance to corrosion.
- Solid plenums for long life and lasting containment Negative-pressure, dual side walls protect from leaks to the exterior environment

Engineering Drawing

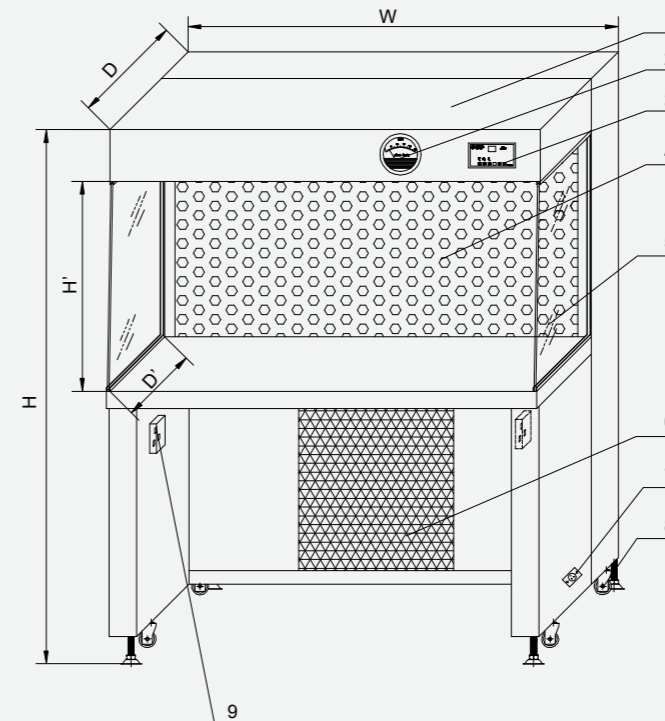

1. Top case lighting/UV lamp
2. Differential pressure gauge
3. Control panel
4. Outlet orifice plate stainless steel orifice plate/HEPA filter inside
5. On both sides of the glass
6. Pre-filter return air (fan inside)
7. Power meter socket (inside the cabinet)
8. Trundle adjusting pin
9. Single - phase dustproof socket (each left and right side under table)

Characteristics and Features

- When programmed ON, an airflow alarm warns of deviations from normal velocities.
- Automated reduced flow mode for enhanced energy efficiency.
- Negative pressure side wall plenums.
- Reduced noise level is designed to enhance user focus.
- Prefilter extends the HEPA filter life and is easily changed by hand without the need of tools.
- UV disinfection (optional) --A UV disinfection light can be fitted into the top of the work space to disinfect the worktop.
- Provides a laminar flow of HEPA-filtered air to meet the most critical contamination requirements.
- Incorporates industry-leading quiet, low-vibration fan/ filter modules.

Airflow Direction

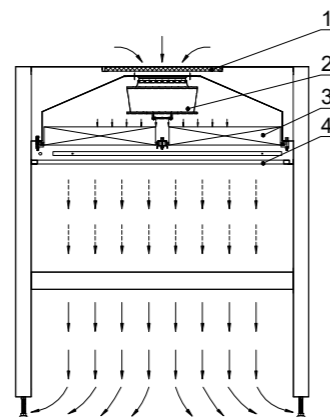

1. Pre-filter
2. Fan
3. HEPA filter
4. Movable homogeneous membrane

Dimensions

Model	Outer Size W×D×H(mm)	Inner Size W'×D'×H'(mm)	Cleanliness Class	Rated Wind Speed (m/s)	HEPA Size L×W×D(mm)/ Quantity	Types
LVCW09-081070	970×770×1800	810×700×550	Class A	0.45±20%	720×610×93 /1	Single Side Vertical Air Supply
LVCW15-130070	1460×770×1800	1300×700×550			590×610×93 /2	Double Sides Vertical Air Supply
LVCW06-082048	900×700×1450	820×480×600			650×540×93 /1	Single Side Horizontal Air Supply
LVCW13-168048	1760×700×1450	1680×480×600			740×540×93 /2	Double Sides Horizontal Air Supply

Laminar Airflow Trolley

Laminar Flow Horizontal or Vertical Trolleys are used for the storage and the transfer of products that are sensitive to contamination, between two classified areas, generally separated by autoclaves. The trolleys are fitted with an independent power supply which keeps the laminar flow constant at any time.



Characteristics and Features

- Product transfers under aseptic conditions.
- Unidirectional flow; vertical or horizontal.
- HEPA gel sealed design.

Technical Specification

- Housing: Body structure fully made in stainless steel SUS304 press-bent metal sheets.
- Filter: G4 pre-filter and H14 HEPA filter
- Ventilation provided by energy efficiency low power consumption motor blower.
- Power supply: Dry battery UPS recovery pack with theoretical battery duration of 2-4 hours starting from full charge status.
- Dop Port: DOP test port at upstream of HEPA filter to personnel for carrying out the HEPA filter integrity test.
- Mobility: Pivoting (360°) castors with brakes.



Product Schematic Diagram

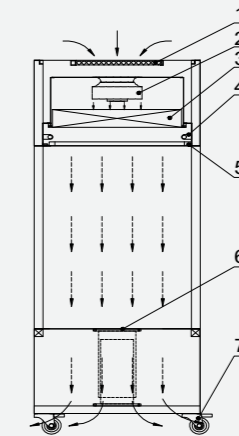

Airflow Direction

1. Pre-filter
2. Fan
3. HEPA filter
4. LED light
5. Movable homogeneous membrane
6. Lifting platform
7. Stainless steel trundle

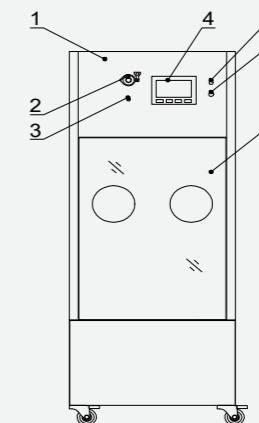

Drawing of Structure

1. Box
2. DOP test port
3. DOP sampling port
4. PLC
5. Buzzer
6. Power button
7. Acrylic seal plate

Dimensions

Model	Outer Size L×W×H(mm)	Inner Size L'×W'×H'(mm)	Rated Air Velocity (m/s)	Cleanliness Class	Power (kW)
LUFT8-072058	800×600×1800	720×580×750	0.45±20%	Class A	0.4
LUFT10-092058	1000×600×1800	920×580×750			0.4
LUFT14-112068	1200×700×1800	1120×680×750			0.5

VHP Sterilization Chamber

VHP(vaporized hydrogen peroxide) Decontamination Chamber is normally used for sterilization of outer surface of any object, which is not suitable for AUTOCLAVE & compatible with HYDROGEN PEROXIDE in vapour phase.



Patent for Invention
 Heating Device for VHP
 Patent No: 201910097348.X

Patent for Invention
 Filter Paper and Filter with Catalytic
 Decomposition for VHP Sterilization Device
 Patent No: 201910880516.2

Patent for Utility Model
 Heating Device for VHP
 Patent No: ZL 201920172562.2

Patent for Utility Model
 VHP Device with Sterilized HEPA Filter
 Patent No: 201922435716.5

Operation Principle

- A built-in VHP generator heats up the hydrogen peroxide, converting it from liquid to vapour, then blown into the chamber, creating a lethal environment capable of killing bacteria, viruses and fungi. Each step of the process is fully controlled, guaranteeing perfect performance.

Application

- VHP Decontamination Chamber is designed for two different zone of area, for transferring of product from lower classified zone to higher classified zone (Non – sterile area to Sterile area), without effecting the balancing of respective zone, Containment free product transfer to higher classified zone. The Unit is especially suitable for GMP regulated pharmaceutical companies manufacturing drugs aseptically.

Features

- Sterilization process <120min to realize multiple sterilization operations one day.
- Fully automatic operate, menu can be saved and invoked.
- Emergency Stop.
- Adopts clean compressing air for vaporization power which can reduce the impact of the pressure differential when taking air from the room.
- Decomposition filter can effectively reduce the concentration of VHP remain Reduce the impact on environment and personnel.
- Through up down side to reduce the inspection space.
- Corner sterilization pass box which will increase factory space utilization ratio, and improve the distribution.
- Very low hydrogen peroxide consumption.

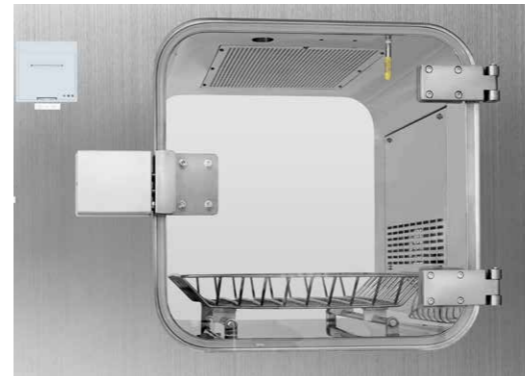

VHP: the Process

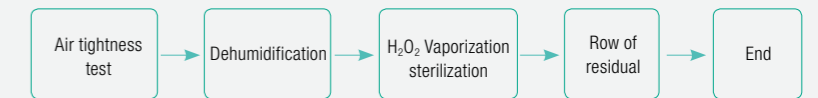

Vaporizer Schematic Draw

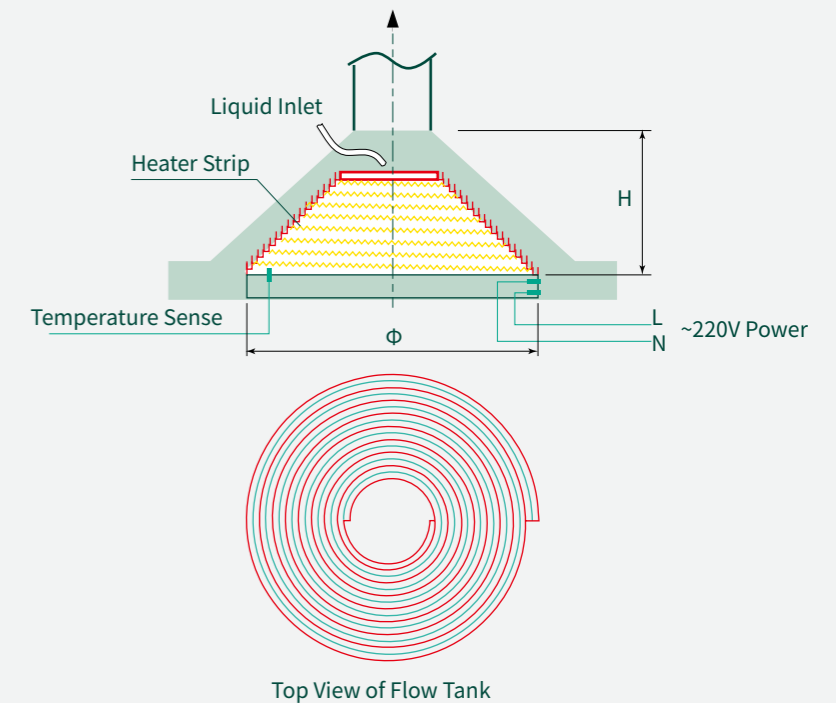

Dimensions

Model	Outer Size WxDxH(mm)	Inner Size W'xD'H'(mm)	Nominal Volume (L)	Cleanliness Class	Sterilization Efficacy	Power (kW)
LATM288	1200×800×2000	600×800×600	288	Class B	6-log	3
LATM512	1400×800×2200	800×800×800	512			
LATM1000	1600×1060×2100	1000×1000×1000	1000			
LATM1440	1600×1260×2300	1000×1200×1200	1440			

Fan Filter Units



Containment System

- High Energy Efficiency
- High Airflow Capacity
- Minimizes cleanroom service downtime with room-side-replaceable fan filter units

Engineering Drawing

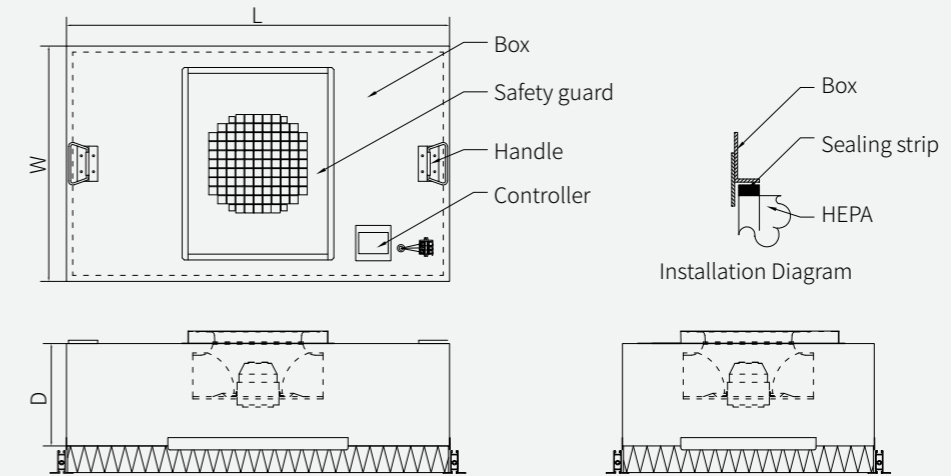

Introduction

- LENGE Fan Filter Units (FFU) are ceiling module diffusers consisting of HEPA-filter, fan and control system. The module is designed to provide unidirectional vertical airflow of filtered, clean air over a cleanroom space by removing harmful airborne particles from recirculating air. FFU creates a positive room pressure that reduces the contamination risk from potential ceiling bypasses.
- FFU models will have three stickers located on the back of the plenum. For ease of troubleshooting assistance, replacement parts, and general factory assistance, it is recommended that the order number, and model line string be used as reference. This information can be found on the Factory Label.

Features

- HEPA (High-Efficiency Particulate Air) filters are rated 99.99% efficient at removing particles ≥ 0.3 microns.
- Painted white, expanded metal face screen.
- Low sound, low watts, low profile, and low operating costs.
- Snap-in pre-filter allows for easy replacement and maintenance (must be removed when ducting directly to the unit).
- Custom sizes and configurations available.

Dimensions

Model	Outer Size LxWxH(mm)	Rated Air Volume and Wind Speed (m ³ /h)/(m/s)	Initial Resistance of Filter (Pa)		Noise (dB)	Power (kW)
			Efficiency For Particles (H14) @MPPS \geq 99.995%	Efficiency For Particles (U15) @0.1 μ m \geq 99.9995%		
LFFU10-117.57	1175x575x350	1000/0.45			57	0.18
LFFU15-117.87	1175x875x350	1500/0.45	100	160	60	0.25
LFFU20-117.117	1175x1175x350	2000/0.45			63	0.37



Reliable Choice for Cleanliness

LENGE Stainless Steel Furnishing Series

LENGE is accredited with the CE certification approved by European Inspection and Certification Company S.A., in accordance with the Pressure Equipment Directive 2014/68/EU and applied technical specification. The certification along with the rigid test report with authoritative technical data assures product liability and customer safety.



Material Quality Stainless Steel

LENGE adheres to quality stainless steel to obtain high-end clean furnishings for customers. SUS304/SUS316L material is corrosion resistance, easy clean, and high cycle life.

Brushed stainless steel

High quality solid brushed stainless steel sheet 1.2mm, which is anti-corrosion.

Aluminum honeycomb or PVC board inside

There are aluminum honeycomb or PVC board filling inside between double stainless steel sheets. It has strong load-bearing performance and difficult to deform.

Laser cutting and blanking



Design

Circular Angle design

The interior of the furnishings is designed with an circular angle, which is easy to clean and no dead corners, in according with GMP.

Technics

Exception many imported production equipment, LENGE also have Sandblasting, Electrolyte Polishing etc several surface treatment production line.

Full welding

There are 10 automatic welding machines. Full welding instead of spot welding, which guaranteed sealing. The welding lines are more elegant.

Sand Blasting Process

Sandblasting technology makes the surface of the furnishings present fine bead sand surface, which adding a pleasant aesthetic feeling, retaining the excellent mechanical properties of stainless steel, and enhancing the corrosion resistance.

Electrolyte Polishing

Making the board color consistent, and lasting luster. Leveling the concave which cannot be polished by machinery. Increasing the surface corrosion resistance and brightness of the furnishings.

CNC bending



Automatic welding



Mechanical Polishing



Stainless Steel Cabinet

Clean Room Wardrobe/Locker

The cabinets are made from stainless steel and are ideal for keeping changing rooms and work areas neat and tidy. This is easier to clean and prevents objects from being placed on top of the cabinet. These lockers are provided with strong doors, handles and locks that ensure security of important objects. Ideal for food service, wash-down and clean room environments.



1

Characteristics and Features

- Chemical resistant - ideal for laboratories containing Corrosive medium.
- Particle-less perfect for the biotech and semiconductor industries.
- Rust-free and moisture proof structure is ideal for wet/high humidity environments.
- Tough surface is ideal for areas subject to heavy impact, heat, and abuse.
- Ease of sanitization is perfect for areas which are subject to continuous cleaning or sterilization.
- Door hinges for sheet steel doors made of stainless steel.
- Wide variety of interior fitting solutions for any requirement.

Dimensions

NO.	1	2	3
Overall Size LxWxH(mm)	1200x450x1800	900x320x1200	1300x450x1800

The dimensions listed are for reference only. All products can be customized according to customer requirements.



Product Details

Design Type	Customized
Overall LxWxH(mm)	Customized
Material	Stainless steel
Surface Finish	Polished
Electrostatic Powder Coating	222,226 silicon rubber etc.
Color	Stainless steel/Customized
Door Type	Customized
Lock Type	Customized
Top Type	Flat/Slant
Door Handle Type	Customized
No. of Lockers/Doors	As Per Client Required
Capacity (kg)	As Per Client Required

Available Option



- With or without door handles for option.



- Cylinder lock with two keys/ code lock for option.



- Flat or slanting top for option.



2



3

Stainless Steel Shoe Rack

Seating Bench with Shoe Lockers



Stainless steel shoe rack with lockers is manufactured from fully welded 304 grade stainless steel in a brushed polish finish. It is compact, hygienic and robust. Moreover, the compartments below the bench provide a convenient storage space with easy access and organization of shoes or other similarly sized items.

Characteristics and Features

- Fully welded 304 grade stainless steel.
- Brushed dull polish finish.
- Available in 316 grade Stainless steel.
- Number of storage bins for option.
- Different lockers for option.
- Different powder-coated colour for option.
- Free standing, stainless steel leg for option.
- Pre-drilled drainage holes encourages easy cleaning for option.
- Customized stainless steel labels or placards for option.

Containment System

- Manufactured from robust, easy to clean, 304 grade stainless steel.
- All corners are fully welded for additional strength and no extra installation at customer site. All edges are ground smooth for safety, and the brushed stainless surface provides a clean look.
- This in-wall storage cabinet features ensure that employees can store their footwear safely and in an organized manner, ensuring quick dress-up/dress-down within a changing room.
- Our twenty years experience provides high quality products and results in a high performance table solution for you.
- Please contact the office for more information, bespoke or simply click enquire on the product to send a direct email to our sales team.

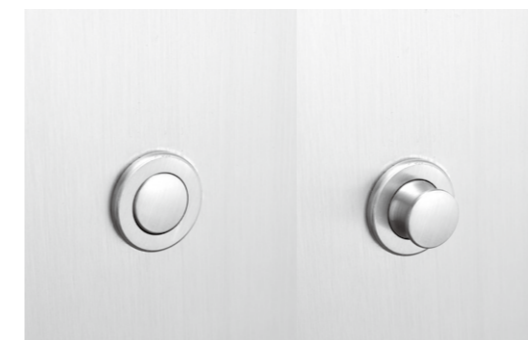

Shoe Bench

Combined Type Shoe Bench & Cross Over Bench



Characteristics and Features

- Manufactured from robust, easy to clean, 304 grade stainless steel.
- All corners are fully welded for additional strength and no extra installation at customer site. All edges are ground smooth for safety, and the brushed stainless surface provides a clean look.
- The shelf below the bench provide a convenient storage space with easy access.

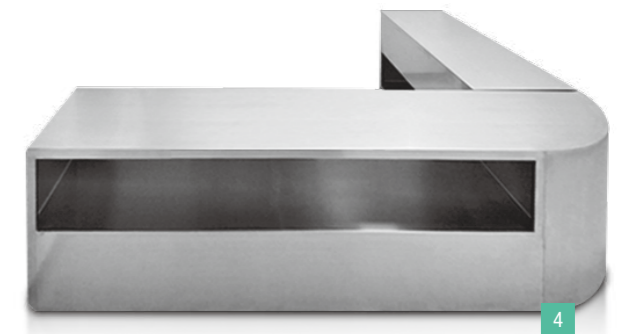

Dimensions

NO.	1	2,3,4
Overall Size LxWxH(mm)	2200x350x600	1200x350x600

The dimensions listed are for reference only. All products can be customized according to customer requirements.

Stainless Steel Sink

Stainless steel sink, which works well in clean rooms, labs, and manufacturing facilities. Manufactured from 304 or 316 non-magnetic stainless steel in a brushed dull polish finish.



Characteristics and Features

- Manufactured from 304 or 316 grade high quality stainless steel.
- Brushed dull polish finish.
- Fully welded construction.
- Crevice free, easy clean surfaces and sturdy design.
- Number of sinks for option.
- Back splash available.
- Upstand strainer available.
- Drains board for option.
- Overflow hole for option.
- Available with various tap options (taps sold separately).



Containment System

- The trolleys come with one, two, three or four compartments, multi sizes for option.
- Features square-corner construction in fully welded, access via a front door with door handle. No extra installation.
- Backsplash, drain boards, overflow hole and faucets for option.
- It is ideally suited for customer with ultra hygiene standards and easy to clean.

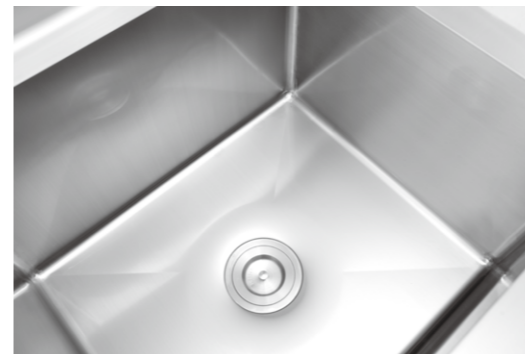
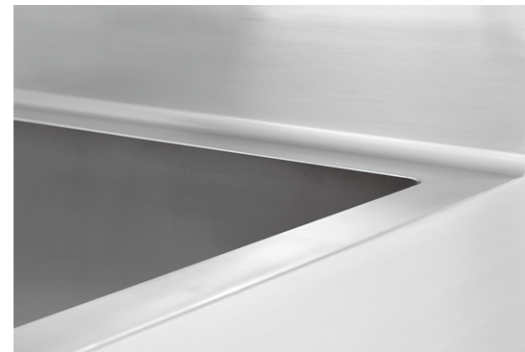

Dimensions

No.	1,2	3,4,5
Overall Size LxWxH(mm)	1200×600×800	600×600×800
Height with the splashboard (mm)	950	950
Depth of the sink (mm)	250	250

The dimensions listed are for reference only. All products can be customized according to customer requirements.

Stainless Steel Trolley

LENGE high quality stainless steel trolleys are manufactured from fully welded 304-grade stainless steel in a brushed dull polish finish. They are ideal for transporting materials, equipment and for short term storage of furnishings in cleanroom, laboratories and other environments that require a focus on hygiene levels. Available as either self-assembly or fully welded



Characteristics and Features

- Manufactured from 304 grade high quality stainless steel.
- Brushed dull polish finish.
- Fully Welded Construction.
- Easy clean and sturdy design.
- Retaining rail available.
- Number of shelves for option.
- Solid or perforated shelves for option.
- 40kg payload per shelf.
- 4 swivel castors, two lockable castors.
- Anti-static or non-marking rubber wheel.
- Wall bump guards.
- Suitable for cleanroom, sterile rooms, food processing and research areas.



Containment System

- The trolleys come with two or three, solid or perforated shelves with raised edges to protect against accidental spills.
- They also come with special non-marking, smooth running 5" cleanroom swivel castors.
- From quiet wheels to shelves with sound-absorbing lining and a 40kg payload per shelf.
- The general purpose trolley is designed complete with wall bump guards and swivel castors, for easy mobility and safety.
- With a range of available sizes, we are confident you will find a trolley to suit your needs.



Dimensions

No.	1,3,4,5	2
Overall Size LxWxH(mm)	1000x500x800	1000x800x1400

The dimensions listed are for reference only. All products can be customized according to customer requirements.

Stainless Steel Table and Bench

Stainless steel table work surface has curved edges for safety. Heavy duty adjustable stainless steel shelf. Suitable for work, pharmaceutical factory, etc.

Stainless Steel Storage Rack

Stainless steel shelving/ladder storage rack for pharmaceutical factory, labs, load per layer: 0-100 kg. All made of stainless steel, and it is durable and practical.

Stainless Steel Sanitary Ware Rack

Stainless Steel sanitary ware rack exclusively use to hang mop. You can customize the size and styles according to your requirements.

LENGE Clean Room Doors/Swing Doors

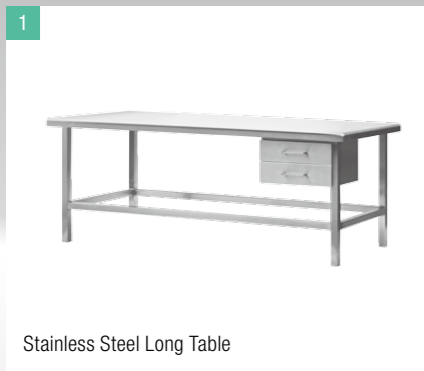

Stainless Steel Long Table

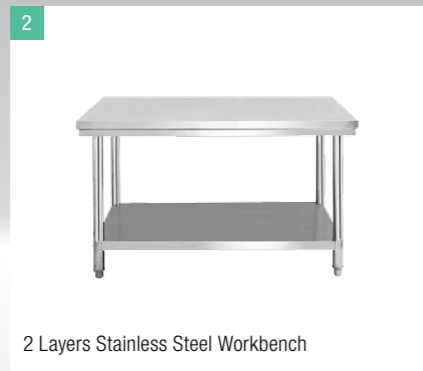

2 Layers Stainless Steel Workbench

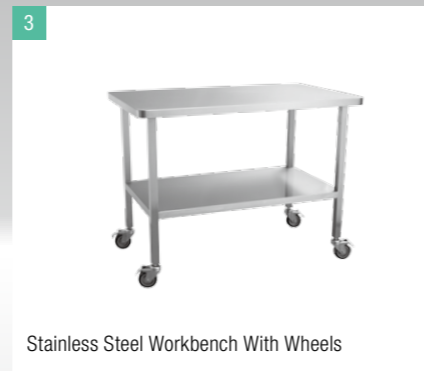

Stainless Steel Workbench With Wheels

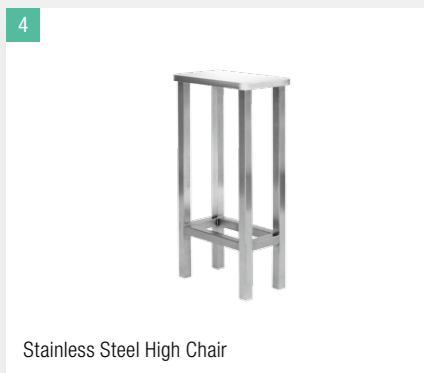

Stainless Steel High Chair

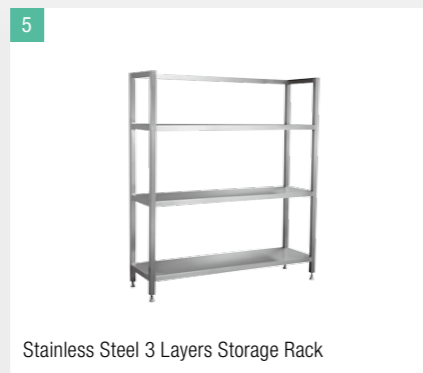

Stainless Steel 3 Layers Storage Rack

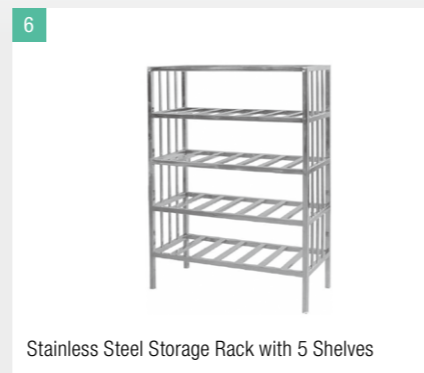

Stainless Steel Storage Rack with 5 Shelves

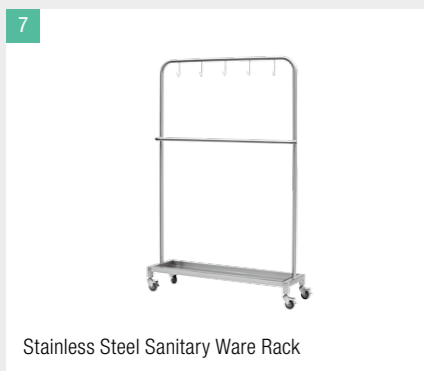

Stainless Steel Sanitary Ware Rack

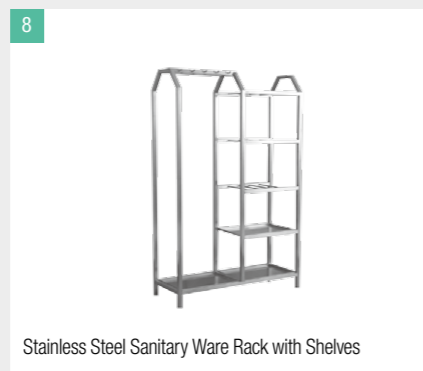

Stainless Steel Sanitary Ware Rack with Shelves

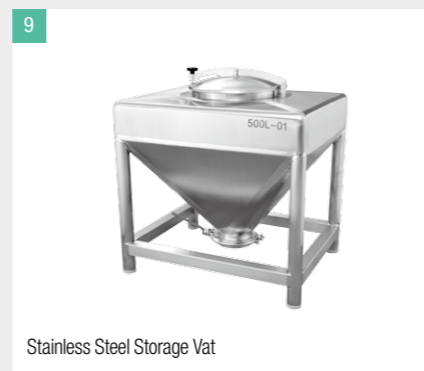

Stainless Steel Storage Vat



LENGE clean room door/swing doors for food or pharmaceutical factories, expressly designed for use in clean rooms, are designed to be perfectly integrated into wall system, and also to be installed on third-party walls, including drywall or masonry.

All components are selected according to criteria of resistance to an intensive use and of minimization of the friction between components in order to avoid the emission of contaminating particles.



S.S Hinge



S.S Handle lock



Drop-down Bottom Seal



NOTES

Please feel free to contact us for series of product catalogs.

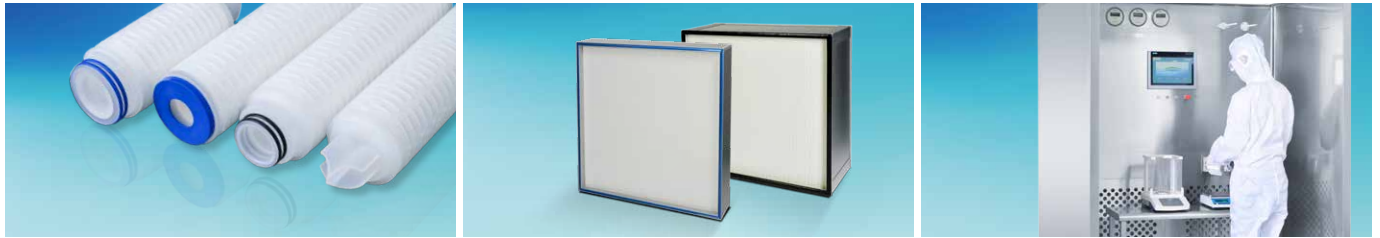

LENGE Purification Equipment Co., Ltd.